

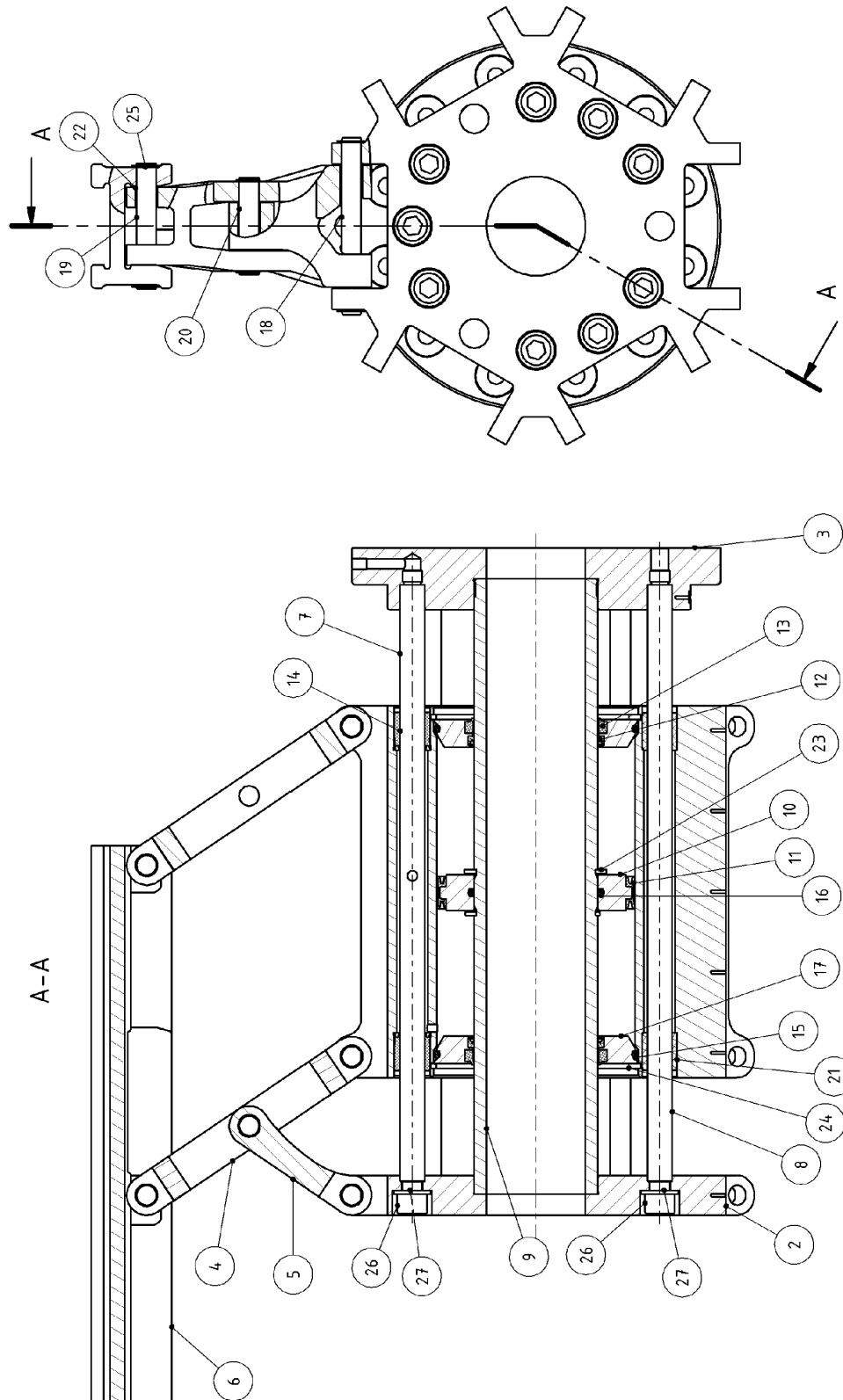

assembly plan (type: C116)



address:

GMG – Gesellschaft für modulare
Greifersysteme mbH
Rodinger Weg 8H • D-59494 Soest
Germany

phone:

+49 (0)2921 - 4062

fax:

+49 (0)2921 - 4042

e-mail:

info@gmg-system.com

homepage:

http://www.gmg-system.com

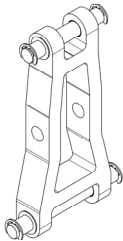
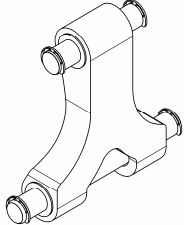
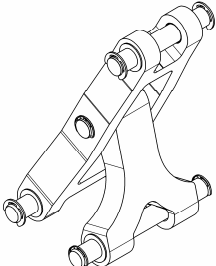

Pos. 4, 5		Link, Crank, Crank Mechanism		
Article	Component	Ident.	Scope of Delivery	
Link	02	LE16	Link (4), Slide Bearing (22), Bearing Pin (18 + 19) and Circlip (25) completely mounted	
Crank	03	KU16	Crank (5), Slide Bearing (22), Bearing Pin (18 + 20) and Circlip (25), completely mounted	
Crank Mechanism	51	KT16	Link (4), Crank (5), Slide Bearing (22), Bearing Pin (18 - 20) and Circlip (25), completely mounted	

Order Number:

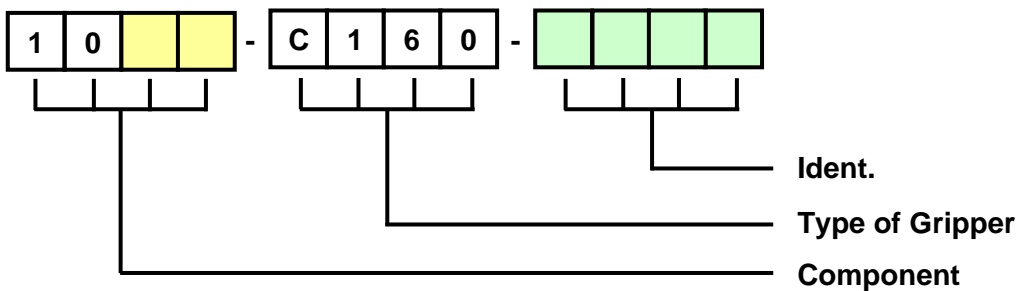

address:

GMG – Gesellschaft für modulare Greifersysteme mbH
 Rodinger Weg 8H • D-59494 Soest
 Germany

phone:

+49 (0)2921 - 4062

fax:

+49 (0)2921 - 4042

e-mail:

info@gmg-system.com

homepage:

http://www.gmg-system.com

Pos. 6		Finger			
Finger Length		Finger Movement			
Length Dimension (F) [mm]	Ident.	Finger Movement	Bore Dimension (H) [mm] (G) [mm]		Ident.
0	000	parallel open parallel close	268	16	A
100	100				B
200	200				
300	300	parallel open swiveling close	332	C	
400	400	swiveling open swiveling close	475		
Special Length	(F) in mm	Finger Type			
		Without Bore			00
		With Bore			01

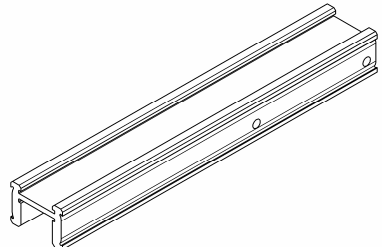

Order Number:

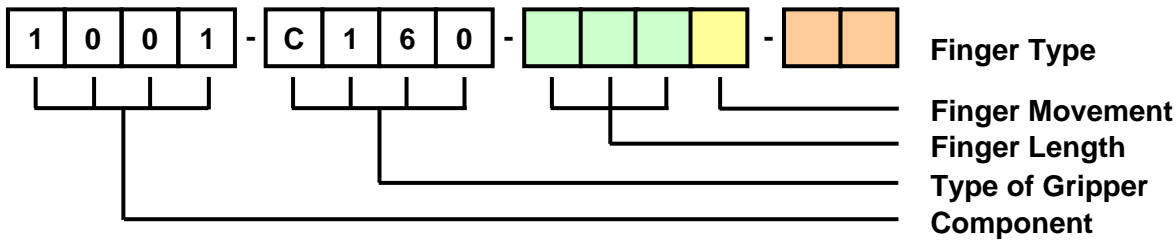

Pos. 14, 15, 16 Bearing Pins

Article	Component	Ident.	Scope of Delivery
Bearing Pin	01	B161	Bearing Pin (18) and Circlip (25)
Bearing Pin	02	B162	Bearing Pin (19) and Circlip (25)
Bearing Pin	03	B163	Bearing Pin (20) and Circlip (25)

Order Number:

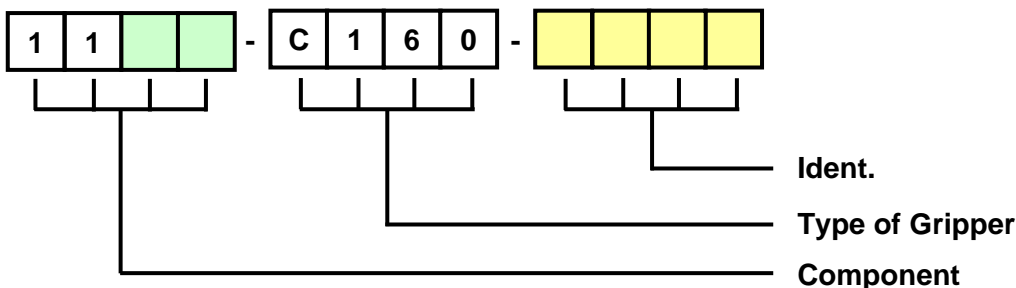

address:

GMG – Gesellschaft für modulare Greifersysteme mbH
 Rodinger Weg 8H • D-59494 Soest
 Germany

phone:

+49 (0)2921 - 4062

fax:

+49 (0)2921 - 4042

e-mail:

info@gmg-system.com

homepage:

http://www.gmg-system.com

Pos. 4, 5, 6 Finger Mechanism

Finger Length		Finger Movement		
Length Dimension (F) [mm]	Ident.	Finger Movement	Bore Dimension (H) [mm] (G) [mm]	Ident.
0	000	parallel open parallel close	268	A
100	100			
200	200	parallel open swiveling close	332	16
300	300			
400	400	swiveling open swiveling close	475	C
Special Length	(F) in mm			
Finger Type				
Without Bore				00
With Bore				01

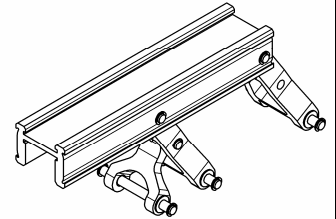

Order Number:

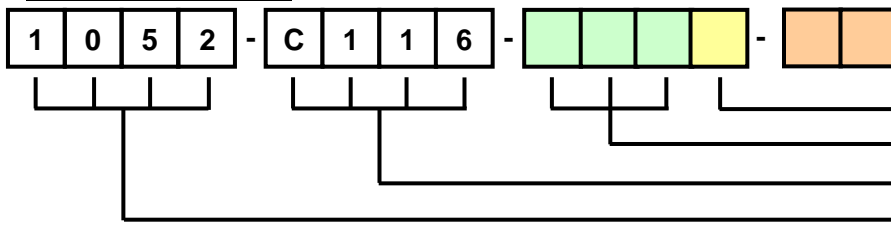

Finger Type

Finge Movement

Finger Length

Type of Gripper

Component

Scope of Delivery
Finger (6), Link (4), Crank (5), Slide Bearing (22), Bearing Pin (18 - 20), Circlip (25), completely mounted

Operating Unit

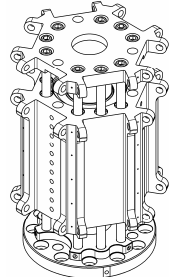
Pos.	Article	Order Number: 1079-C116-BE16
1-3, 7-17, 21, 23-24, 26-27	Operating Unit	

address:

GMG – Gesellschaft für modulare Greifersysteme mbH
Rodinger Weg 8H • D-59494 Soest
Germany

phone:

+49 (0)2921 - 4062

fax:

+49 (0)2921 - 4042

e-mail:

info@gmg-system.com

homepage:

http://www.gmg-system.com

Spare Part Kit 1 (Piston Unit)

Pos.	Article	Quantity	Order Number: 1080-C116-KE16
10	Piston	1	
9	Piston Pipe	1	
11	Piston Sealing	1	
16	O-Ring	1	
23	Circlip	2	

Spare Part Kit 2 (Cylinder Cover)

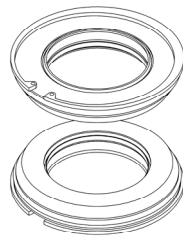
Pos.	Article	Quantity	Order Number: 1081-C116-ZD16
17	Cylinder Cap	2	
12	Seal Ring	2	
13	Stripper	2	
15	O-Ring	2	
24	Circlip	2	

Spare Part Kit 3 (Sliding Rods)

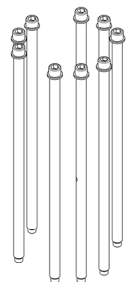
Pos.	Article	Quantity	Order Number: 1082-C116-FS16
7	Sliding Rod with Bore	2	
8	Sliding Rod	7	
26	Hexagon Socket	9	
27	Spring Washer	9	

address:

GMG – Gesellschaft für modulare Greifersysteme mbH
 Rodinger Weg 8H • D-59494 Soest
 Germany

phone:

+49 (0)2921 - 4062

fax:

+49 (0)2921 - 4042

e-mail:

info@gmg-system.com

homepage:

http://www.gmg-system.com

Spare Part Kit 4 (Head Plate)

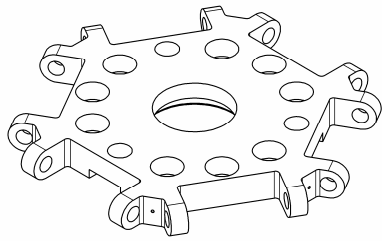
Pos.	Article	Quantity	Order Number: 1083-C116-KP10
2	Head Plate	1	

Seal Kit 16

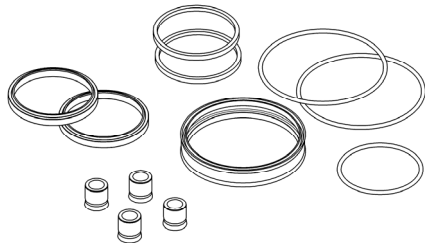
Pos.	Article	Quantity	Order Number: 1090-C116-DS16
11	Piston Seal	1	
12	Seal Ring	2	
13	Stripper	2	
14	Multiple Element	4	
15	O-Ring	2	
16	O-Ring	1	

Gas Spring (Object Retention)

Scope of Delivery	Force [N]	Order Number:
Gas Spring incl. Collar Nut (2x)	700	1006-C116-GF70

Shock Absorber

Scope of Delivery	Order Number:
Shock Absorber including Casing and Nut	1004-C116-SD16

Proximity Switch

Scope of Delivery	Order Number:
Proximity Switch (PNP) with Extension	1049-C116-PN01
Proximity Switch (PNP) without Extension	1049-C116-PN00

address:

GMG – Gesellschaft für modulare Greifersysteme mbH
 Rodinger Weg 8H • D-59494 Soest
 Germany

phone:

+49 (0)2921 - 4062

fax:

+49 (0)2921 - 4042

e-mail:

info@gmg-system.com

homepage:

http://www.gmg-system.com

Proximity Switch Kit

<i>Scope of Delivery</i>	Order Number:
<i>1 Proximity Switch (PNP) with Extension, Magnetic Carrier, Fixation Bar for 2 proximity switches minimum, fixing screws</i>	1050-C116-PN01
<i>1 Proximity Switch (PNP) without Extension, Magnetic Carrier, Fixation Bar for 2 proximity switches minimum, fixing screws</i>	1050-C116-PN00

Mounting Elements for Proximity Switch

<i>Scope of Delivery</i>	Order Number:
<i>Magnetic Carrier, Fixation Bar for 2 proximity switches minimum, fixing screws</i>	1005-C116-BESG

We only deliver to the INCOTERMS latest edition.
All printing and clerical errors are subject to correction without liability!
Prices and delivery times can only be provided through an individual quote.